



MANTEGNA



- Linea arrotondata priva di spigoli e facile da pulire.
- Perno di scorrimento, cromato rettificato e lappato.
- Boccole di scorrimento autolubrificante.
- Paracolpo su carrello in gomma vulcanizzata.
- Coperchio supporto vela smontabile.
- Parafetta rimovibile in acciaio inox con incastrò rapido a baionetta.
- Tutte le minuterie acciaio inox.
- Copertura inferiore con accesso diretto ai componenti elettrici.
- Scheda elettronica commutabile 110-220V monofase o 220-380V trifase.
- Affilatoio con vaschetta inferiore di protezione.
- Sistema di tenuta stagna su puleggia.
- 48 mm di distanza fra lama e corpo macchina.
- Estrattore lama di serie.

- *Innovative rounded design and no sharp edges or visible screws*
- *Chrome plated ground and lapped slide rod.*
- *Self lubricating slide rod bushings.*
- *Vulcanised rubber stops on carriage.*
- *Removable support cover for thickness gauge plate.*
- *Stainless steel slice deflector with snap-on bayonet fitting.*
- *Stainless steel screws and fittings.*
- *Bottom cover for accessing electrical components.*
- *Changeover electronic circuit 110-220V single or 220-280V three phase.*
- *Built in sharpening tool with bottom protection.*
- *Enclosed and sealed belt pulley.*
- *48 mm distance between blade and motor.*
- *Standard Blade Removal Tool (BRT).*



MANTEGNA 300 BS1 TOP

MANTEGNA

- Manopole in plastica.
- Piedini in gomma.
- Pulsanti IP 67 in plastica

MANTEGNA TOP

- Manopole alluminio.
- Piedini in alluminio telescopici con base in gomma.
- Pulsanti IP 67 in acciaio inox.
- Kit manutenzione e sanificazione in pratica valigetta.

MANTEGNA BS1

- Braccio stringisalumi con staffa chiodata inox rimovibile per la pulizia.

MANTEGNA VCO

- Particolarmente richieste nei mercati nordici.
- Piatto a vasca per tagliare ogni tipo di prodotto.
- Staffa blocca prodotto in alluminio smontabile.
- Staffa con chiodi in acciaio e denti fresati sul lato lama.
- Disponibile anche nella versione con braccetto mobile.

MANTEGNA

- Plastic knobs.
- Rubber feet.
- Plastic pushbuttons with IP67 protection rating.

MANTEGNA TOP

- Knobs aluminum.
- Aluminium telescopic feet with rubber base.
- Stainless steel pushbuttons with IP67 protection rating.
- Maintenance tool kit.

MANTEGNA BS1

- Easy to remove stainless steel meat grip arm.

MANTEGNA VCO

- Specially required by the Northern European marketplace
- Product table designed to slice all types of products.
- Removable aluminum end weight.
- Designed with grooves: nails underneath.
- Available with double articulating arm on end weight



MANTEGNA 300 BS1



MANTEGNA 300 VCS

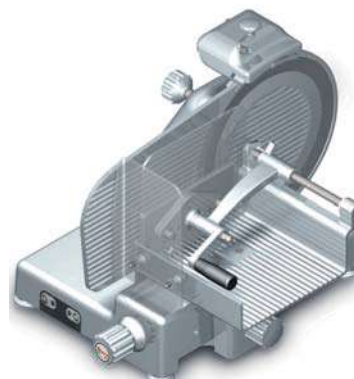

MANTEGNA 300 VCO BM TOP



Zavorra smontabile BS1
Removable food pusher BS1

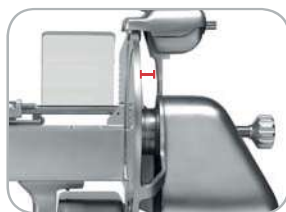

Ampio spazio tra lama e corpo macchina
More space between blade and body machine



Zavorra smontabile VCS
Removable food pusher VCS



Comandi per le versioni Top, di serie
Standard controls for Top versions

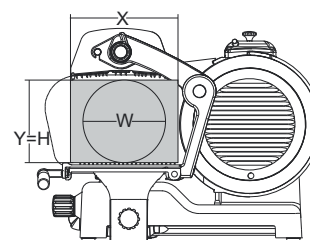
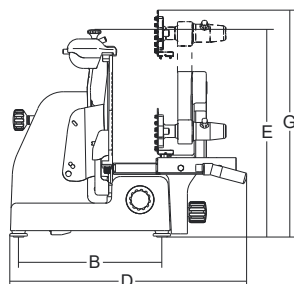
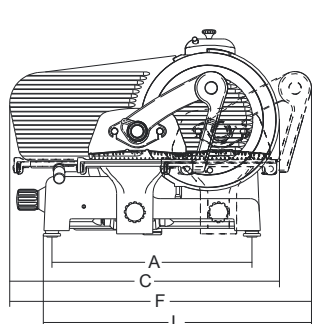

						A	B	C	D	E	F	G	L	X	Y	H	W			
	mm-inch	wall-Hp	mm	mm	mm	mm	mm	mm	mm	mm	mm	mm	mm	mm	mm	mm	mm	kg	mm	kg
Mantegna 300 BS1	300/12"	275/0,37	29	310	300x270	468	338	635	600	500	750	695	650	270	230	230	230	36,5	870x840x750	51,5
Mantegna 300 VCS	300/12"	275/0,37	29	310	340x250	468	338	635	685	500	720	560	610	250	225	225	225	36	870x840x750	52
Mantegna 300 VCO	300/12"	275/0,37	29	310	280x260	468	338	635	652	500	677	520	610	260	230	230	230	35	870x840x750	50
Mantegna 300 VCO BM	300/12"	275/0,37	29	310	280x260	468	338	635	585	500	677	660	610	260	230	230	230	36	870x840x750	51
Mantegna 330 BS1	330/13"	275/0,37	29	310	300x270	468	338	645	600	515	750	705	630	270	245	245	245	37	870x840x750	52
Mantegna 330 VCS	330/13"	275/0,37	29	310	340x250	468	338	645	685	515	720	560	580	250	235	235	235	37	870x840x750	53
Mantegna 330 VCO	330/13"	275/0,37	29	310	280x260	468	338	645	652	515	677	520	585	260	245	245	245	36	870x840x750	51
Mantegna 330 VCO BM	330/13"	275/0,37	29	310	280x260	468	338	645	585	515	677	660	585	260	245	245	245	37	870x840x750	52
Mantegna 350 BS1	350/14"	370/0,50	29	310	300x270	468	338	660	600	530	750	715	630	270	255	255	255	38	870x840x750	53
Mantegna 350 VCS	350/14"	370/0,50	29	310	340x250	468	338	660	685	530	720	560	580	250	245	245	245	38	870x840x750	54
Mantegna 350 VCO	350/14"	370/0,50	29	310	280x260	468	338	660	652	530	677	520	585	260	255	255	255	38	870x840x750	53
Mantegna 350 VCO BM	350/14"	370/0,50	29	310	280x260	468	338	660	585	530	677	660	585	260	255	255	255	38	870x840x750	53

TOP



MANTEGNA 300 VCO TOP



MANTEGNA 300 VCS TOP