



TC MONTANA

tritacarne
meat grinders



- Costruzione in acciaio inox AISI 304 lavabile con spruzzo d'acqua.
- Riduttore ermetico a bagno d'olio.
- **Gruppo macinazione:**
- Completamente in acciaio inox AISI 304
- Studiato per grandi prestazioni
- Alte prestazioni anche in seconda e successive passate
- Produzione oraria effettiva 1.100 Kg/h (42)
- Produzione oraria teorica 3.500 Kg/h
- Rimanezza carne interno bocca 50-90 g
- Perno trascinatore in acciaio inox
- **Con esclusivo sistema brevettato di controllo presenza piastra e ghiera (CE)**
- Perno elicica in acciaio temperato
- Veloce smontaggio gruppo macinazione per pulizia e sanificazione
- Collo introduzione quadro per maggiore velocità di carico
- Ampia tramoggia 563 x 900 h. 120 mm con micro di sicurezza
- Comandi in acciaio inox IP 67 con inversione di marcia (versione CE)

- *AISI 304 stainless steel construction, can be sprayed.*
- *Sealed oil-bath gear box.*
- **Grinding set:**
- *Completely made of AISI 304 stainless steel*
- *Designed for high performance*
- *High performance even product is processed two or more times.*
- *Hourly output: 1.100 Kg (actual) (42)*
- *Hourly output: 3.500 kg (possible)*
- *Unprocessed meat inside grinding set at working cycle end: 50-90 g.*
- *Stainless steel drive pin.*
- **Exclusive, patented plate and ring nut detection system (CE)**
- *Tempered steel worm pin.*
- *Grinding set is quickly disassembled of faster cleaning and sanitation.*
- *Square feeding "neck" allows for faster processing cycles.*
- *Large feeding hopper 563x900 h. 120 mm with safety microswitch*
- *IP 67 water protected stainless steel controls with reverse (on CE versions).*



TC 42 MONTANA Y12



P. 121



TC 32 MONTANA Y12



TC 32 MONTANA Y12



Opzionale: sistema di protezione interbloccato per uso piastre con foro > 8 mm.
 Optional: interlock protection for more than 8 mm holes plates.



Opzionale: paraspruzzi
 Optional: splash guard



Pedaliera opzionale
 Optional pedal controls

Optional disponibili:

- Comandi FULL CONTROL per gestione accessori
- Tramoggia gigante lt. 78
- Paraspruzzi inox
- Comando a pedale
- Bocca unger parziale inox
- Bocca unger totale inox
- Bocca lunga
- Sistema di protezione interbloccato per uso piastre con foro > 8 mm.
- Ampia disponibilità di piastre e coltelli specifici
- FORMAT S
- FORMAT A

Dotazione standard:

- Coltello e piastra diam. 4,5 autoaffilanti inox
- Pestello
- Attrezzo estrazione elica e piastre
- Manuale uso e manutenzione

Standard accessories:

- Stainless steel self-sharpening knife and 4,5 mm plate
- Pestle
- Worm and plate removing tool
- Use and maintenance manual



Estrattore piastre
 Plates removal tool

Optional available:

- FULL CONTROLS for accessories handling
- Larger feed tray lt. 78
- Stainless steel splash guard
- Pedal control
- Stainless steel 1/2 unger grinding set
- Stainless steel total unger grinding set
- Longer head
- Interlock protection for more than 8 mm holes plates (An interlock protection system is required in order to utilize more than 8 mm holes plates).
- Wide selection of plates and knives
- FORMAT S
- FORMAT A

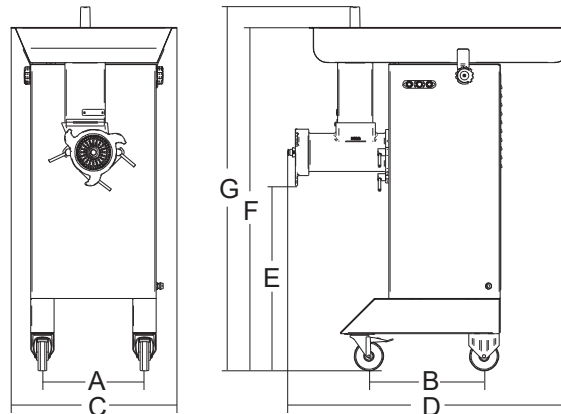

					A	B	C	D	E	F	G			
	watt/HP	phv/3ph	kg/h.	ø mm	mm	mm	mm	mm	mm	mm	mm	kg	mm	kg
TC 32 Montana Y12	2.940/4	1ph/3ph	700	4,5	348	393	564	911	654	1169	1237	90	1050x950x1960	115
TC 32 Montana Y12 Bocca lunga	-	-	-	-	348	393	564	1005	654	1169	1237	93	1050x950x1960	118
TC 42 Montana Y12 Hp 5	3.675/5	1ph/3ph	800-1000	4,5	348	393	564	973	631	1171	1241	112	1050x950x1960	137
TC 42 Montana Y12 Hp 7	5.145/7	1ph/3ph	1200-1300	4,5	348	393	564	973	631	1171	1241	112	1050x950x1960	137
TC 42 Montana Y12 Bocca lunga	-	-	-	-	348	393	564	1063	631	1171	1241	132	1050x950x1960	157
TC 42 Montana Y12 Tramoggia gigante	-	-	-	-	348	393	626	1125	631	1282	1282	128	1050x950x1960	153
TC 42 Montana Tramoggia gigante + Bocca lunga	-	-	-	-	348	393	626	1215	631	1282	1282	148	1050x950x1960	173