

# IP 30-50 M Y14



## impastatrici per carne meat mixers



- Costruzione in acciaio inox Aisi 304.
- Potente motore.
- Riduttore a bagno d'olio con ingranaggi elicoidali temperati e rettificati.
- Sistema di protezione ingranaggi con doppio paraolio.
- Coperchio con micro di sicurezza.
- Pala in acciaio inox Aisi 304 facilmente rimovibile senza attrezzi.
- Sportello vasca apribile per rimozione pala e impasto.
- Comandi in acciaio inox IP 67 con inversione.

### Opzioni:

- Gambe inox basse, medie e alte con ruote.
- Tramoggia aggiunta ingredienti.

- *AISI 304 stainless steel body.*
- *Powerful.*
- *Oil bath reducer with hardened and ground helical gears.*
- *Gear box with double sealing system.*
- *Safety microswitch on the cover.*
- *Removable AISI 304 stainless steel mixing arm (no tools required).*
- *Front outlet opening for shaft removal and product unload.*
- *Stainless steel IP 67 protection rated controls with reverse.*

### Optionals:

- *Short, medium, long legs with wheels.*
- *Feeding tray to add ingredients.*



### IP 50 M Y14

Gambe con ruote opzionali  
Optional legs with wheels



IP 30 M Y14



IP 30 M Y14



**IP 30 M Y14**



Comandi IP 67 in acciaio inox  
Stainless steel IP 67



**IP 50 M Y14**



Opzione tramoggia per aggiunta ingredienti  
Optional feed tray for add ingredients

**IP 30-50 M Y14 optionals**

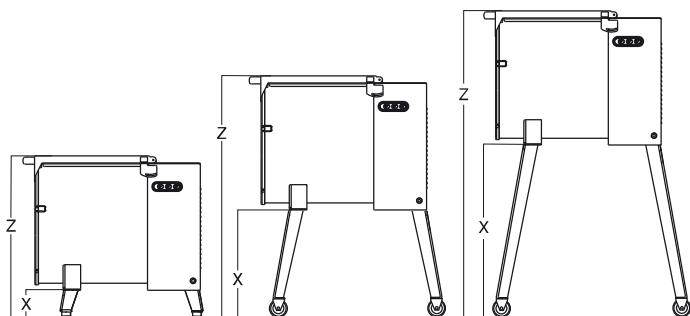

Gambe basse con piedino  
*Short legs with feet*

IP 30 M Y14  
X: 150 mm / Z: 650 mm  
IP 50 M Y14  
X: 150 mm / Z: 720 mm

Gambe medie con ruote e freno  
*Medium legs with wheels and brake*

IP 30 M Y14  
X: 440 mm / Z: 940 mm  
IP 50 M Y14  
X: 440 mm / Z: 1010 mm

Gambe alte con ruote e freno  
*Longer legs with wheels and brake*

IP 30 M Y14  
X: 610 mm / Z: 1110 mm  
IP 50 M Y14  
X: 610 mm / Z: 1180 mm

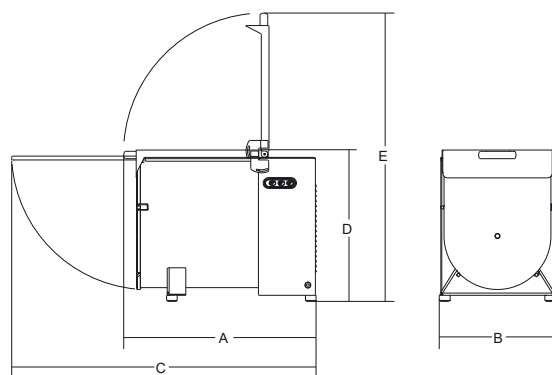

	watt/HP		mm	l/kg	mm	mm	mm	mm	mm	kg	mm	kg
<b>IP 30 M Y14</b>	1ph 1.100/1,5 3ph 1.472/2	1ph/3ph	300x400	42/30	680	365	1120	530	975	49	720x570x770	59
<b>IP 50 M Y14</b>	1ph 1.100/1,5 3ph 1.472/2	1ph/3ph	410x480	88/50	750	465	1250	595	1120	59	870x840x760	74